



FSQ Prises ATEX

Mode de protection:

Type de protection: II 2 G EEx d IIC
 Classe de température: T6
 Indice de protection: IP66
 Zones : 1-2



Description:

Boîtier en alliage d'aluminium. Différents modèles avec différentes intensités possible.

Sur demande:

Disponible avec switch automatique

Schéma:

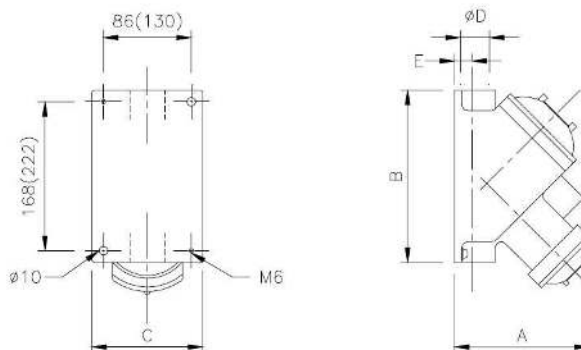

Intensité (A)	Pôles	Dimensions (mm)					Références	Poids (Kg)
		A	B	C	D	E		
15	2+T	160	192	110	1"	25	FSQ 215	2.3
25	3+T	160	192	110	1"	25	FSQ 325	2.4
25	4+T	190	192	110	1"	25	FSQ 425	2.5
60	3+T	190	146	155	1.1/2"	35	FSQ 360	3.2

BP PLUGS SERIES



Cables entries	Suitable socket	Code	Weight (g.)
3/4"	FSQ 215	BP 215	340
3/4"	FSQ 325	BP 325	350
3/4"	FSQ 425	BP 425	360
1"	FSQ 360	BP 360	370

