



BAT53 250W ATEX Floodlight

Protection mode:

Type of protection: II 2G Ex de IIB T3
 Amb Temp : -20°C to +55°C
 Protection degree: IP65
 Certificates: LCIE 05 ATEX 6143 / 01
 LCIE 07 ATEX 6106
 IEC Ex CQM 07.2004



Description:

BAT53-250W series explosion-proof floodlights are designed for large area lighting in the oil field, offshore platform, dock or factory, etc, where is filled with IIA, IIB, explosive gas mixture.

- Explosion protection to
 -CENELEC
 -IEC
- Integral structure with the lamp, the ballast, convenient to maintain
- Can be used in Zone 1 and Zone 2.
- Explosion-proof ignitor, quick start, steady performance, long service life.
- Housing in cast aluminium alloy or welded stainless steel, powder-coated.
- Toughened glass, impact resistant, high light transmission.

Drawing:

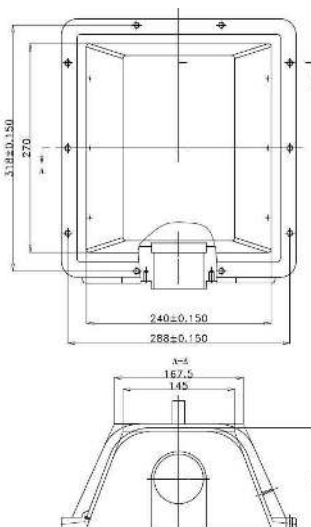

Catalogue number logic

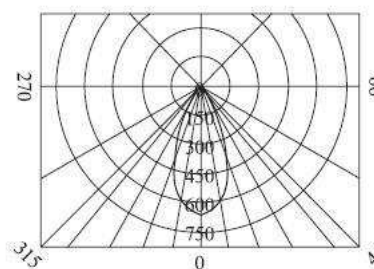
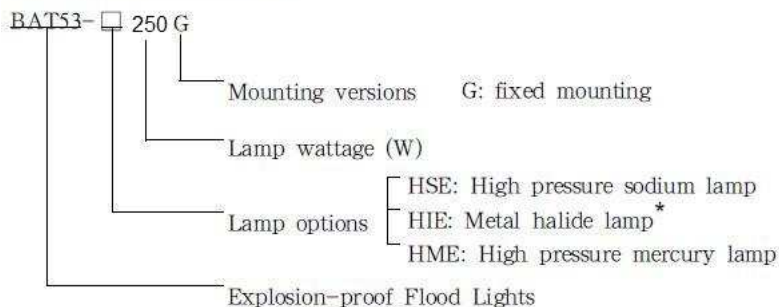

Luminous intensity distribution (cd/1000lm)

* standard normally in stock, others on request



BAT53 250W ATEX Floodlight

Explosion-proof floodlights BAT53-G250	
Explosion protection	
Gas explosion protection	Ex II 2G Ex de IIB T3
Certificates	
For gas explosion protection	LCIE 05 ATEX 6143 / 01
	LCIE 07 ATEX 6106
	IEC Ex CQM 07,2004
Explosion protection to	En 50014-1997 + A1 +A2; EN 50018-2000; EN 50019-2000 (BAT53-G250)
	EN 60079-0:2004; EN 60079-1:2004; EN 60079-7:2003 (BAT53-G400)
	eqv IEC 60079-0: 2004; IEC 60079-1: 2003; IEC 60079-7: 2001
	IEC 61241-0:2004; IEC 61241-1:2004
Material	
Housing	Aluminium alloy, powder-coated, yellow; independant relamp hole for easy maintenance, no need open the glass cover. Adjustable lamp holder keeps the lamp in the center of lamp case. The floodlights can be adjusted in +30°to -30°for large area lighting,
Ballast	Chock ballast, quick start, steady performance.
Ignitor	Explosion-proof ignitor, ATEX certificate No: LCIE 07 ATEX ____
Compensation	It is not supplied unless user requests,
Lamps	
Lamp holder	E40
Available lamp and wattage	High pressure sodium lamp (HSE): 250W
For BAT53-G250	High pressure merury lamp (HME): 250W
	Metal halide lamp (HIE): 250W*
	Note: With HPI European standard lamp available ballast
Rated voltage	AC 220V 50Hz/ (200V - 240V)
Earthing protection	M5 (earthing bolt inside and outside the light fittings)
Degree of protection	IP65
Connection	Terminals 3 x 1,5 - 2,5 mm ² (L+N+PE)
Hub	
BAT53	2-M25 1,5
Cable gland	With cable gland DQM - I M25 x 1,5 (carbonate steel), and seal stopping plug on the other entry,
Available cable outer diameter	Φ10 - Φ14 (mm)

***Sur stock**

Enclosure	Available lamp wattage (W)			Lamp holder	Weight
	Metal halide lamp	High pressure mercury lamp	High pressure sodium lamp		
BAT53-250	250	250	250	E40	13 kg
Avec Ballast électronique					