



CSA/X stainless steel without hinges

Protection mode:

Type of protection: II 2 GD - EEx e II / EEx ed IIC
 Class of temperature: T6-T5
 Protection degree: IP 65
 Certificate: INERIS 05 ATEX 0035



Description:

The CSA / X enclosures are squared or rectangular shaped and they have a cover with kasket which is connected to the body of the enclosures by screws.

Technicals data:

Materials :

Boby and Cover: Stainless steel AISI 304.
 Equipment plate: galvanized steel.
 Gasket: Neoprene.

On request :

Stainless steel AISI 316L
 Equipment plate made in stainless steel
 Components (pushbuttons, pilotlights, switches, ...)
 Drain / Breath valve
 Window
 Wiring
 Cable glands

Technical drawing:

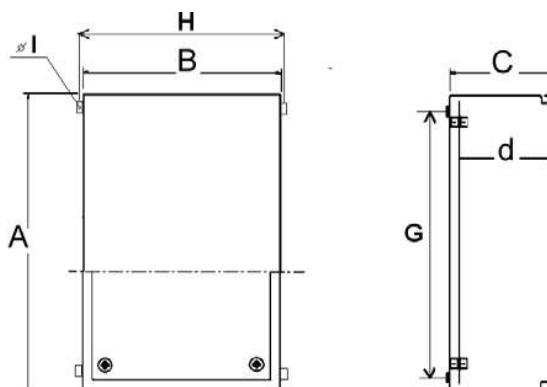

Type	Dimensions (mm)								
	External			Fixing			Height	Equipment Plate	
	A	B	C	G	H	øl	d	h	w
CSA / X1	150	150	80	100	200	10	58	100	135
CSA / X1A	150	150	120	100	200	10	98	100	135
CSA / X2	150	300	80	250	200	10	58	285	135
CSA / X2A	150	300	120	250	200	10	98	285	135
CSA / X3	200	200	120	150	250	10	98	185	150
CSA / X4	200	300	120	250	250	10	98	285	150
CSA / X5	300	300	120	250	350	10	98	285	250
CSA / X6	200	400	120	350	250	10	98	385	150
CSA / X7	300	400	120	350	350	10	98	385	250
CSA / X8	400	400	120	350	450	10	98	385	350
CSA / X9	200	500	120	450	250	10	98	485	150
CSA / X10	300	500	120	450	350	10	98	485	250
CSA / X11	200	600	120	550	250	10	98	585	150
CSA / X12	300	600	120	550	350	10	98	585	250
CSA / X13	400	600	120	550	450	10	98	585	350
CSA / X14	400	800	120	750	450	10	98	785	350