



EFS Switch IIB / IIC

Protection mode:

16A model

Type of protection: II 2GD Ex d IIB/IIC / Ex tD A21
 Class of temperature: T6
 Protection degree: IP65
 Ambient Temp : -20/+50°C
 Zones : 1-2-21-22



Description:

Enclosure in light alloy with external bolts and screws in stainless steel. | 7000 external epoxyvinyl coating.
 Entries: 2x 3/4" UNI6125 (supply with 1 cable gland + 1 plug)
Max I = 20A (AC1) - 690 V a.c.

On request:

Available with locking movement.

EFS IIC version only with 16A models

Technical data:

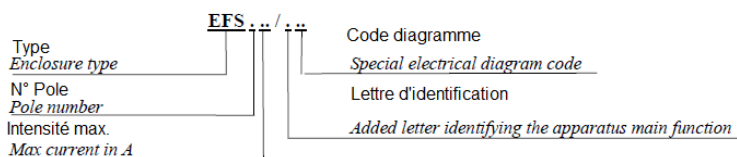

Technical drawing:

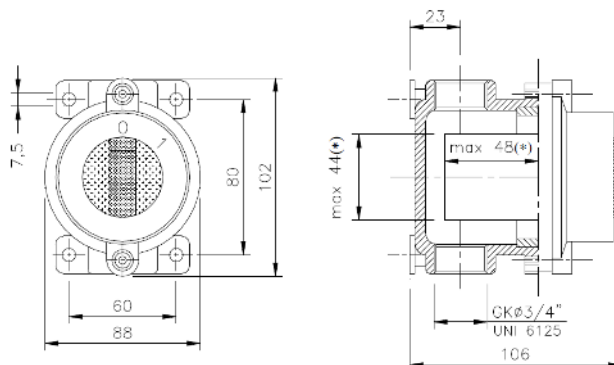

Dimensions table:

Contacts		Code	Poids / Weight (g)
Switch unipolaire	Unipolar switch	EFS 115	700
Switch bipolaire	Bipolar switch	EFS 215	700
Switch tripolaire	Three pole switch	EFS 315	700
Switch tétrapolaire	Tetrapolar switch	EFS 415	700
Commutateur unipolaire	Unipolar commutator	EFS 115/C	700
Commutateur bipolaire	Bipolar commutator	EFS 215/C	700
Commutateur tripolaire	Three pole commutator	EFS 315/C	700
Déviateur unipolaire	Unipolar deviation switch	EFS 115/D	700
Déviateur bipolaire	Bipolar deviation switch	EFS 215/D	700
Déviateur tripolaire	Three pole deviation switch	EFS 315/D	700



EFS Switch IIB / IIC

Protection mode:

Type of protection: II 2GD Ex d IIB/IIC / Ex tD A21
 Class of temperature: T6
 Protection degree: IP65
 Ambient Temp : -20/+50°C
 Zones : 1-2-21-22

32A/63A model



Description:

Enclosure in light alloy with external bolts and screws in stainless steel.
 RAL 7000 external epoxyvinyl coating.
 Entry: 2x 3/4" UNI6125 (supply with 1 cable gland + 1 plug)
Max I = 63A (AC1) - 690 V a.c.

On request:

Available with locking movement.

Technical data:

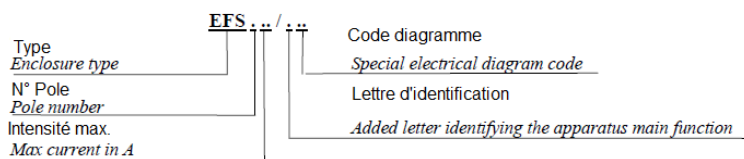

Technical drawing:

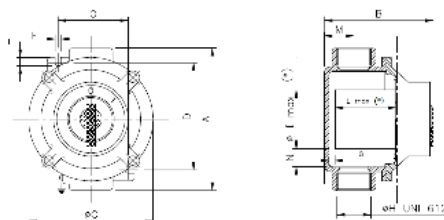

Dimensions table:

Jusqu'à Up to	Dimensions														Poids (g) Weight (g)
	A	B	C	D	E	F	G	H	I(*)	L(*)	M	N	O		
Max 32A	156	118	131	108	7	15	5	1"	70	63	30	13	76	1300	
Max 63A	195	145	167	140	9	19	7	1.1/2"	90	81	41	21	95	2200	

Contacts		Code	Poids / Weight (g)
Switch tripolaire	Three pole switch	EFS 325	1300
Switch tétrapolaire	Tetrapolar switch	EFS 425	1300
Switch tripolaire	Three pole switch	EFS 332	1300
Switch tétrapolaire	Tetrapolar switch	EFS 432	1300
Switch tripolaire	Three pole switch	EFS 340	2300
Switch tétrapolaire	Tetrapolar switch	EFS 440	2300
Switch tripolaire	Three pole switch	EFS 363	2300
Switch tétrapolaire	Tetrapolar switch	EFS 463	2300