



RTFI206CTM401 ATEX Antenna 450-470MHz

Mode of protection:

Type of protection: II 2G Ex d IIB
 Class of temperature: T6
 Ambient temp: -20/+40°C
 Zones: 1-2

Description:

ATEX antenna 450-470MHz for gas zones (1 & 2). Lightweight and compact, **body in stainless steel AISI316L**, antenna in nickel plated brass. Maximum power output dissipated 2W. Unarmoured cable gland M20 kit **in stainless steel AISI316L** (seals 5.5/8 - 8/10.5 - 10.5/13mm). TNC female connector. Hazardous tank level monitoring, offshore platforms, chemical processing, power plants...



References:

RTFI206 CTM401 – 0

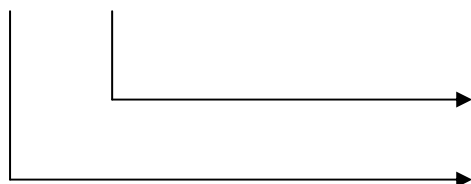

Length of cable

0 : without cable
 5 : 5 meters of cable
 10 : 10 meters of cable
Others length on request

Antenna

450MHz to 470MHz

Enclosure model

RTFI206

References:

RTFI206CTM401 450MHz to 470MHz

Other models on request:

RTFI206CTM800 Dual band 824-896 MHz & 1850-1990 MHz
RTFI206CTM801 Dual band 801-940 MHz & 1901-2000 MHz
RTFI206CTM900 902-928MHz
RTFI206CTM5000 5.0 GHz
RTFI206CTM2400 2.4GHz
RTFI206CTM1500 1,575.42MHz

Antenna technicals data :

Bandwidth: 450 MHz to 470 MHz
 Impedance: 50 Ω
 Gain: 0.0 dBi
 Maximum power: 2 Watts
 Connector type: TNC female
 Mounting base: 20mm (M20)
 7 joule impact rating
 Weight: 1.06 lbs., 0.48 kg
 Maximum length including
 TNC connector: 5.85", 148.6mm

Approx height (mm):

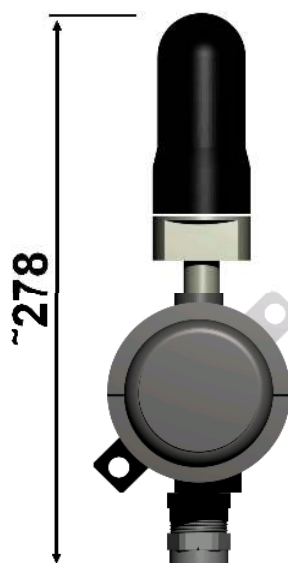



RTFI206CTM401 ATEX Antenna 450-470MHz

Drawing:

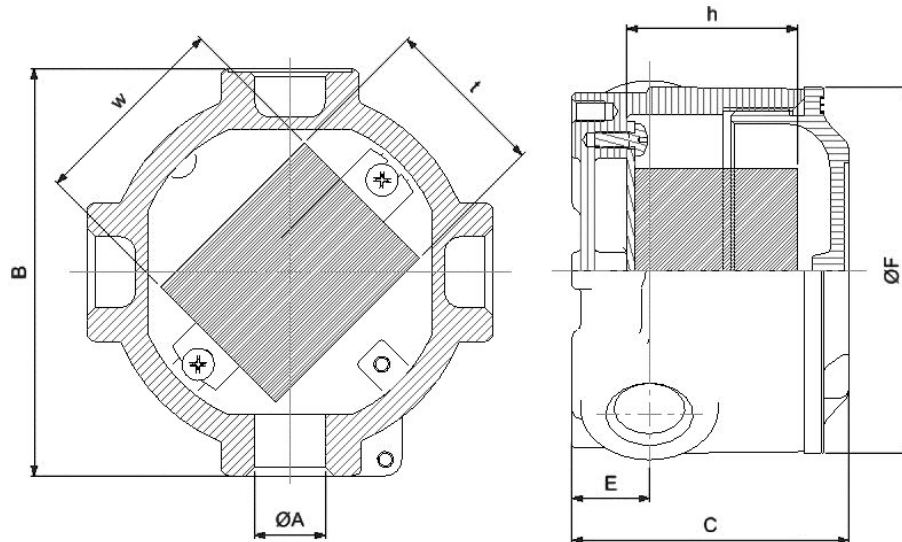

Enclosure dimensions	ØA	Dimensions externe (mm)					Dimensions interne (mm)			Volume elec. (dm ³)	Poids (kg)
		External dimensions (mm)					Internal dimensions (mm)				Weight (kg)
		B	C	D	E	F	h	W	t		
RTFI206CTM401	M20	100	68	9.5	22.5	22.5	40	50	35	0.070	1.25



Fixation	Dimensions (mm)						Poids (kg)
Bracket	A	B	C	D	E	F	Weight (kg)
KF6S	126	18	3	6.5	10	108	50

Example with furniture cable

