



CCF12AMS12048 ATEX MS120 SWITCH

Protection mode:

Type of protection:

EX II 2GD

Ex d IIB ou IIB+H2 T6 or T5 or T4 or T3 Gb

Ex tb IIIC T85°C or T100°C or T135°C or T200°C Db IP66

Protection degree : IP66

Ambient temperature : -20 / +40°C
(-40/-50/+50/+60°C possible on request)

T° Cable :

80°C or 95°C or 130°C or 175°C

Certificates :

INERIS 15 ATEX0010X, IECEx INE 15.0011X



Description:

Aluminium enclosure ATEX / IECEx for explosive atmospheres. Fastening, hinges and screws in stainless steel. Internal epoxy RAL 2004, external epoxy RAL 7000.

Drawing :

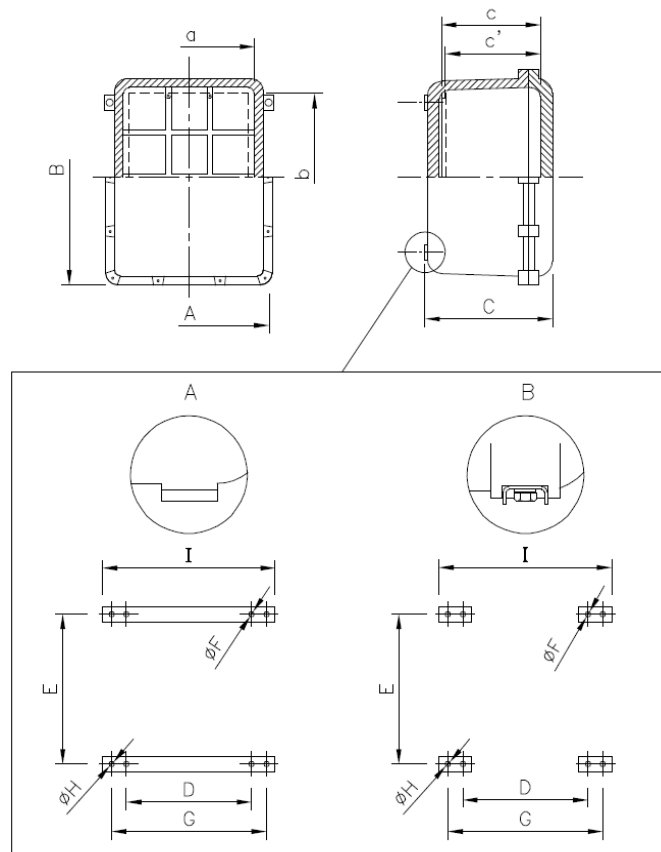



CCF12AMS12048 ATEX MS120 SWITCH

Dimensions :

Model	External dimensions (mm)			Internal dimensions (mm)				Fixing (mm)							Weight (kg)
	A	B	C	a	b	c	c'	Type	D	E	F	G	H	I	
CCF12AMS12048	550	750	300	436	636	240	230	B	445	570	M12	515	13	550	90

Fastening:

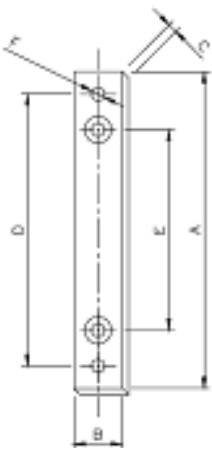

Model	Dimensions (mm)			Distance (mm)			Weight (g)
	A	B	C	D	E	F	
SJ12	550	40	8	515	445	13	1350

SWITCH MS120 MERAKI



Model	Dimensions	Weight	Interface	Capacity
MS120-48FP-HW	44x440x340mm	5,7kg	<ul style="list-style-type: none"> • 48 x 10/100/1000BASE-T Ethernet RJ45 • 4 x 1G SFP uplink • RJ45 management port 	107 Gbps

Specifications to download here :

https://meraki.cisco.com/lib/pdf/meraki_datasheet_ms120.pdf